

PRODUCTIVE ACCURACY

710 A SERIES

PRECISION GRINDING ON FLEXIBLE
CONTINUOUS NON-METALLIC MATERIALS

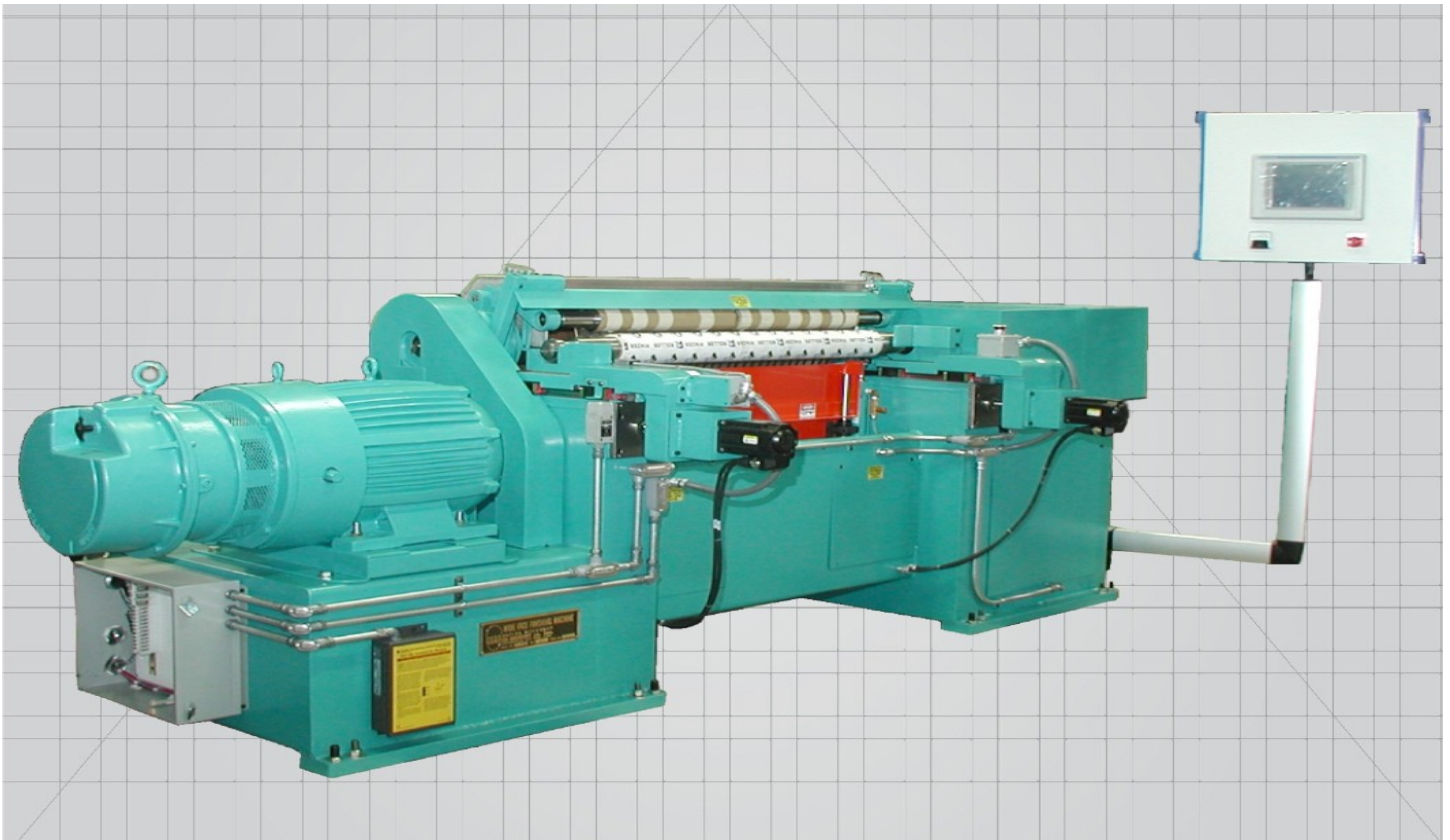

AVAILABLE IN WIDTHS UP TO 52 INCHES

CURTIN-HEBERT MACHINES

11 Forest Street P.O. Box 511
Gloversville, New York 12078-0511
PH 518-725-7157 FAX 518-773-3805

EMAIL: www.info@curtinhebert.com

The heart of the machine is a dynamically balanced cylinder to which industrial coated abrasive is applied. The cylinder is drilled for water circulation to help diffuse friction heat, preventing distortion of the .0005" concentricity.

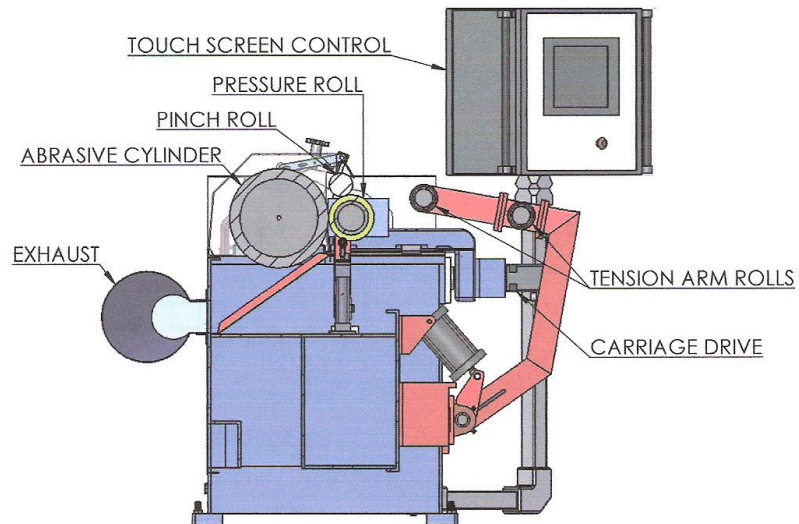
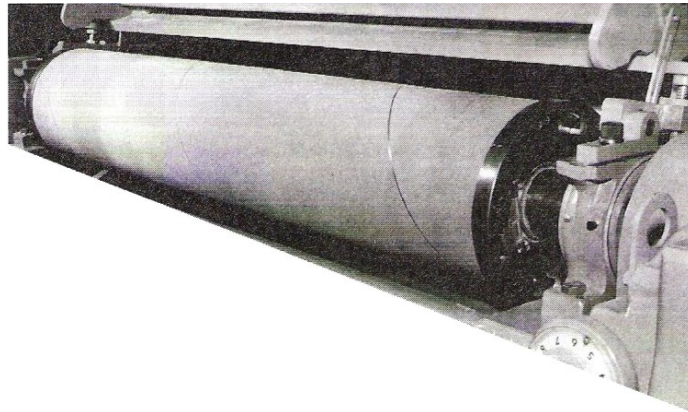

Demonstration equipment available at our Gloversville Plant.
Send or bring us your samples or finishing problems.